

Examination of cryogenic filters for multistage RF filtering in ultralow temperature experiments

V V Zavyalov¹, S A Chernyaev², K V Shein², A G Shukaleva² and K Yu Arutyunov^{1,2}

¹ Kapitza Institute for Physical Problems, RAS, Moscow, Russian Federation

² National Research University Higher School of Economics, Moscow Institute of Electronics and Mathematics, 109028, Moscow, Russia

E-mail: zav@kapitza.ras.ru

Abstract. Cryo-filters are essential while studying electronic properties of nanoscale structures at very low temperatures. In this report we present the simple measuring methodology and experimental impedance characteristics of customized lumped filters cooled down to 4.2K in the 10Hz-500MHz frequency range. In particular, we tested the home-made permalloy-core RL filters, the MurataTMChip Ferrite Bead filter, and the ToshibaTMAmobeadsTMcores. We use the high-frequency generalization of four-terminal sensing method to account for the wiring retardation effects, which are important when working with ultralow temperature systems.

1. Introduction

During electron transport measurements at very low temperatures ($T < 100$ mK) rather small external disturbances might lead to a noticeable overheating. The inevitable external electromagnetic interference (EMI) noise, picked-up and transmitted through electric wires, results in a mismatch between the electron T_e and the phonon T_{ph} temperatures $P \sim W(T_e^5 - T_{ph}^5)$, where P is the power dissipated at the sample with volume W [1]. Hence, for sufficiently small nanoelectronic systems the effect might be clearly pronounced. Multiple methods have been suggested to reduce the undesired electron heating [2]. Among them, the utilization of various RF filters to cut the impact of noisy EMI environment is the most common ones. So far this problem remains relevant [3, 4, 5, 6, 7].

To measure an RF filter's characteristics typically rather expensive broadband network analyzers should be used. The test sample needs to be directly connected to the analyzer via special certified cables, that is only possible for measurements conducted at room temperature.

To check the filters installed in the cryostat it is necessary to use additional cryo-wiring which leads to the mismatch of impedance between transmission line and load, that may distort the results, especially at high frequencies. Here we describe a simple high-frequency generalization of four-terminal sensing method to account for the wiring retardation effects. We also demonstrate the effect of cooling on the impedance-frequency characteristics of several home-made and customized filters.



2. The measuring scheme

The schematic diagram of the measurements is presented in Fig.1. For testing filters we use the top loading insert that operates in a standard liquid helium transport dewar with a 12 mm bore. The sample (Z_x) is mounted in a cylindrical copper shield at the bottom of the insert. Four thin coaxial cables (Z) of the same length of 1200 ± 2 mm pass from the oscilloscope's and generator's terminals to the sample. The two of them go to the sample directly and represent a current sensing circuit, the two others are connected in series with the resistors R_1 and represent a circuit for voltage measurements.

To measure the frequency response of samples we use the 4-channel oscilloscope TektronixTMTDS3054 with sampling rate of 5GS/s, 500 MHz bandwidth, and simultaneous recording of 10^4 readings per channel with 9-bit resolution. This gives us the ability not only to find frequency, amplitudes and phases of the signals U_1, U_2, U_3 (Fig.1), but also to control the presence of frequency harmonics in the case that the sample has nonlinear properties. For the oscilloscope's synchronization we use the signal U_0 .

As RF signal source we use Agilent TechnologiesTMPSG CW signal generator E8257D (for high frequencies) and Stanford Research SystemsTM15 MHz synthesized function generator DS340 (for lower frequencies). In our case, characteristics of the oscilloscope are significant. As for the RF source it does not impose any special requirements, and it can be replaced by any appropriate device.

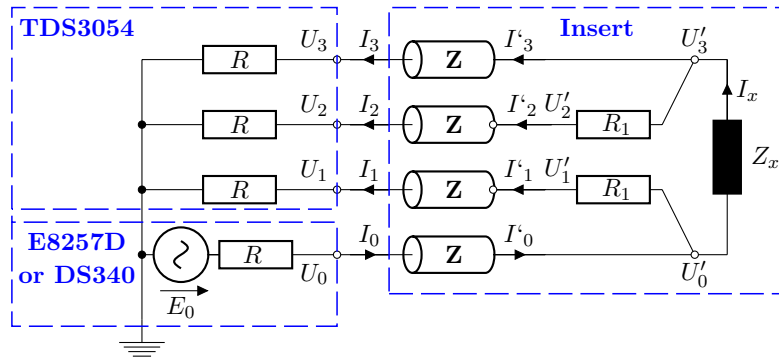

Figure 1. Schematic of the experiment. $R=50 \Omega$ corresponds to oscilloscope and oscillator impedances. $R_1=250 \Omega$ corresponds to low inductance metal resistors. Z stands for 1.2 meter long coaxial cables (PK50-0,6-23).

In this work we deal with lumped filter samples. To test them at liquid helium temperatures we need to use cables, and account for their retardation effects. We can circumvent this limitation by introducing the complex current/voltage transformation matrix Z :

$$\begin{bmatrix} U'_k \\ I'_k \end{bmatrix} = \begin{bmatrix} \cosh(\gamma l) & |Z| \sinh(\gamma l) \\ \frac{\sinh(\gamma l)}{|Z|} & \cosh(\gamma l) \end{bmatrix} \begin{bmatrix} U_k \\ I_k \end{bmatrix}, \quad k = 0..3.$$

where γ denotes the complex propagation constant, l is the length, and $|Z|$ is the characteristic impedance of the cable. Using condition $I_k = U_k/R$, $k=1..3$ we get:

$$U'_k = \left(\cosh(\gamma l) + \frac{Z}{R} \sinh(\gamma l) \right) U_k \equiv a \cdot U_k, \quad I'_k = \left(\frac{1}{Z} \sinh(\gamma l) + \frac{1}{R} \cosh(\gamma l) \right) U_k \equiv b \cdot U_k$$

Given that $U'_2 - U'_3 = I'_2 R_1$, and $U'_1 - U'_0 = I'_1 R_1$ we end up with a simple expression for the frequency-dependent impedance Z_x as function of complex parameters U_1, U_2, U_3 :

$$Z_x(f) = R_1 \frac{(U_1 - U_2)U_3}{(U_3 - U_2)(U_3 + U_2)} \quad (1)$$

Recall that the amplitudes and phases of U_1, U_2, U_3 as well as frequency f are determined from the oscillograms.

The assumption that all four cables are identical allows to exclude their properties from the expression. Moreover, the result does not depend on amplitude of the testing signal, which allows the use of simple non-stabilized generators.

3. Frequency characteristics of various filters

Cryostat for ultralow temperature experiments should be equipped with a multistage filtration system which may consist of EMI filters at room, as well as, liquid He temperatures. One may also add some cryogenic low-pass filters thermally anchored to 1-K pot, to mixing chamber and experimental cell. Our task was to measure characteristics of various filters to evaluate the possibility of their usage in a multistage filtration system.

3.1. Permalloy-core inductor (RL filter).

For fabrication of the magnetic core we used permalloy tape with thickness of 0.1 mm and width of about 11 mm, which was wound on a cylindrical template, forming the magnetic core of a toroidal shape with inner and outer diameters of 2 mm and 4.5 mm, respectively. The core was annealed in vacuum. On that core 20 turns of a NbTi/CuNi superconducting wire of 0.1 mm diameter were wound forming an inductance with room temperature DC resistance $R_{DC} = 23 \Omega$.

One can notice that despite the expected pure reactive behavior of our filter, it is resistive in the range of 10 – 50 MHz, which can be attributed to eddy-currents in permalloy[8]. It is the positive observation for the filtering problem, though it is evident, that our filter design is far from optimal.

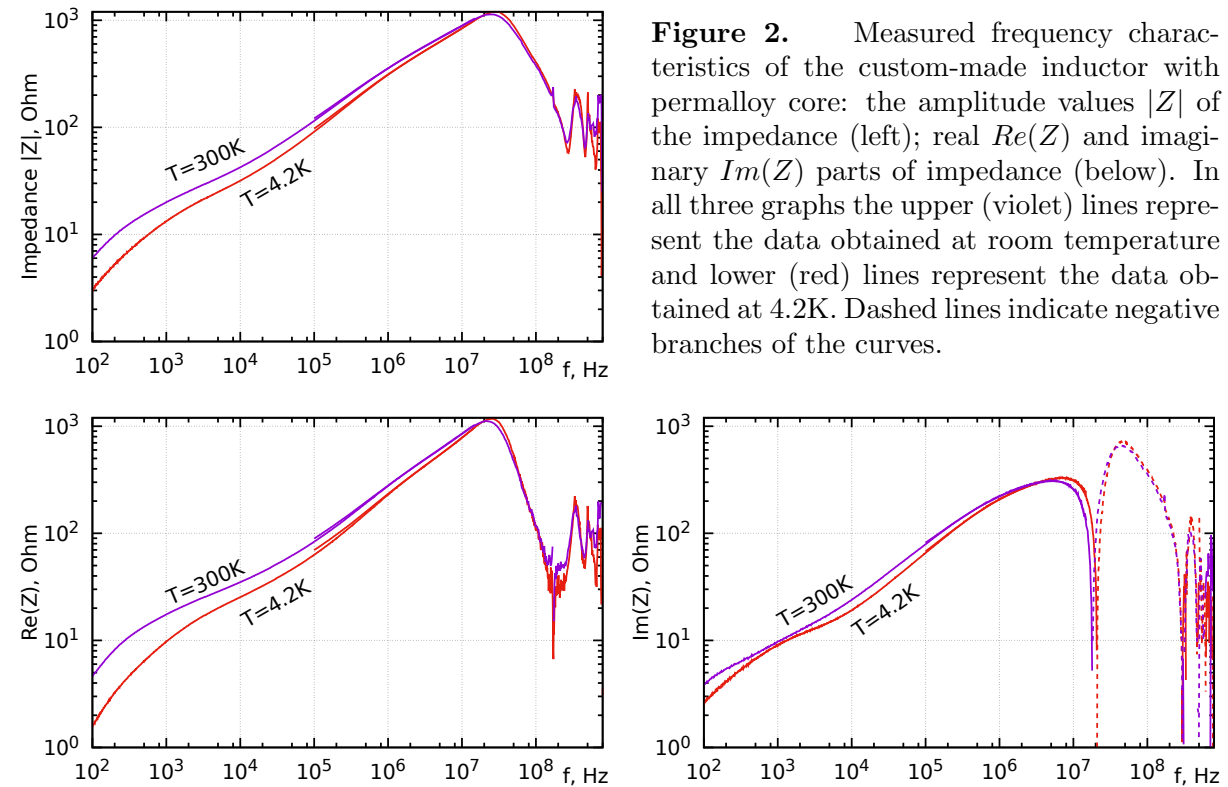

3.2. MurataTM Chip Ferrite Bead EMI suppression filter.

EMI suppression filters from MurataTM are widely used in modern electronics as a universal noise suppression component for frequencies ranging from a few MHz to a few GHz. They are easily available, cheap and well documented[9]. In the rated operational temperature range of -55C to +125C Chip Ferrite Bead acts like a micro inductance in the low frequency range. At high frequencies, however, the resistive component of the inductor constitutes the main part of the impedance.

For testing we choose the product BLM18HG102SN1 which is a EMI suppression filter of the Ferrite Beads type. It should be noted that experimentally measured characteristics of this filter (at room temperature) remarkably coincide with those obtained by modeling of its equivalent circuit [10].

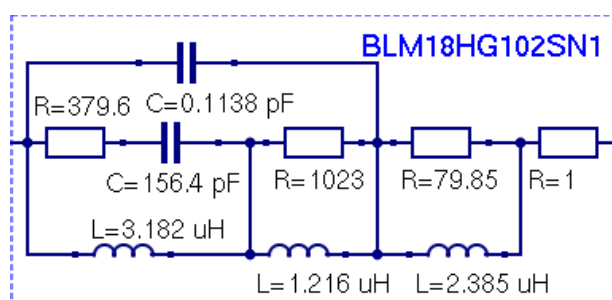

Figure 3. Equivalent circuit for BLM18HG102SN1 filter based on the parameters listed in [10] The manufacturer indicates the following information for the product:

- Shape: 0603 SMD.
- Operating temperature: (-55 to 125°C).
- DC resistance: 1.6 Ω.
- Impedances at 100 MHz and 1 GHz: 1 kΩ.

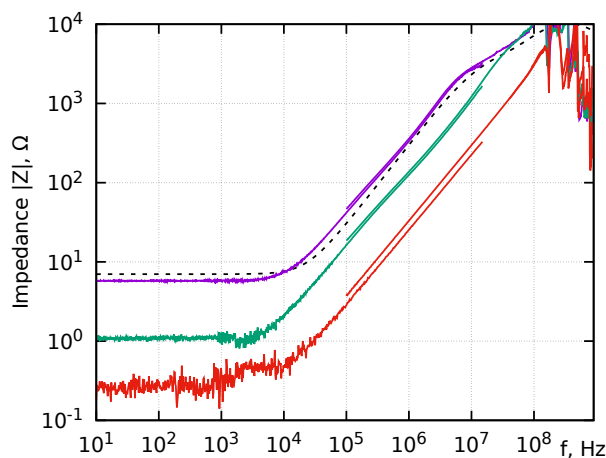
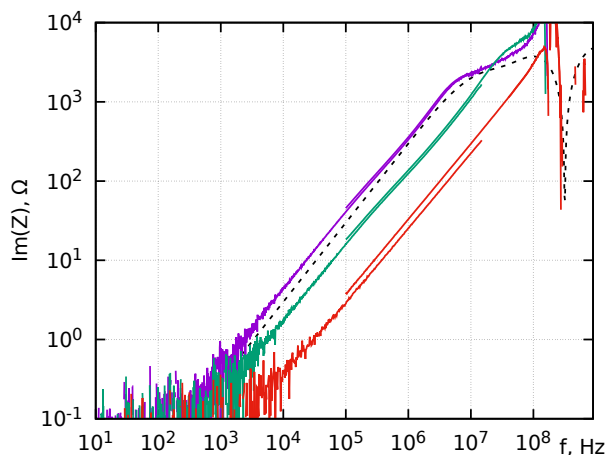
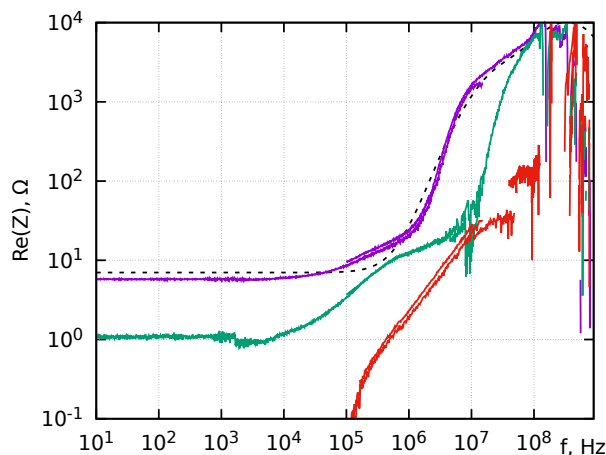

Figure 4 Measured frequency characteristics of seven BLM18HG102SN1 chips connected in series: the amplitude values $|Z|$ of the impedance (left); real $Re(Z)$ and imaginary $Im(Z)$ parts of impedance (below). In all three graphs the dashed lines represent the data calculated from the equivalent circuit; upper (violet) lines represent the data obtained at room temperature; middle (green) lines represent the data obtained at 77K, and lower (red) lines represent the data obtained at 4.2K.



3.3. *ToshibaTM AMOBEADSTM ferrite core AB3X2X6W.*

The amorphous noise suppression devices (AMOBEADSTM) suppress rapid changes in current which could otherwise lead to electrical noise in various circuits. Because of their square-shaped magnetic hysteresis behavior, amorphous noise suppression devices provide very large inductance when the current crosses zero (i.e. changes sign). This large inductance effectively blocks any further current changes [11].

For testing we choose the ferrite core AB3X2X6W which is an amorphous noise suppression device. We were unable to find the manufacturer information about the minimal working temperature for this product but suspected that it can be low. The core is a hollow cylinder with inner and outer diameters of 1.5 mm and 4 mm, respectively; its length is 7.5 mm. For fabrication of the RL filter we wound 50 turns of a NbTi/CuNi superconducting wire of 0.1 mm diameter. The resistance of this coil comprises 36 Ω .

In the low frequency range, the specimen shows a nonlinear behavior, which is manifested in the form of a hump on the curves near 200 Hz. With the increase of the signal amplitude, the position of the hump moves towards higher frequencies, and its height increases. The graphs shown in Fig.5 was obtained for $U_0 = 0.2$ V.

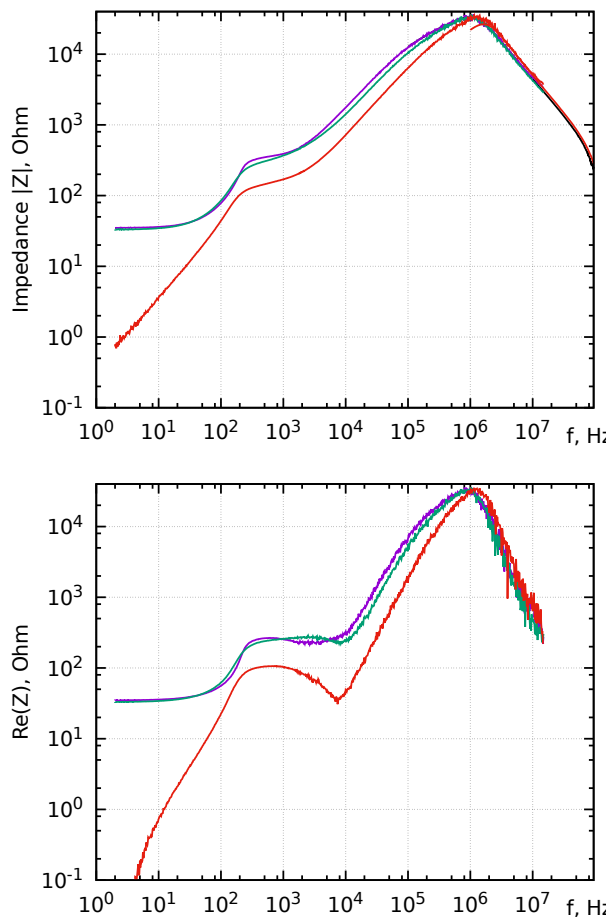

Figure 5. Measured frequency characteristics of inductor with a ToshibaTM AmobeadsTM ferrite core AB3X2X6W: the amplitude values $|Z|$ of the impedance (left); real $Re(Z)$ and imaginary $Im(Z)$ parts of impedance (below). In all three graphs the upper (violet) lines represent the data obtained at room temperature; middle (green) lines represent the data obtained at 77K, and lower (red) lines represent the data obtained at 4.2K. Dashed lines indicate negative branches of the curves.

4. Conclusions

We have developed a simple method of measuring the frequency dependence of electrical impedances in a wide (10 Hz-500 MHz) frequency range without usage of expensive network analyzers. The method enables measurements to be made on samples cooled down to low temperatures.

As an example of using the method, MurataTMChip Ferrite Beads EMI filters and ToshibaTMAmobeadsTMcores, whose low temperature characteristics were not rated previously, were measured. It was found, that in series connected MurataTMBLM18HG102SN1 chips may serve as a high-efficiency EMI filter at room, as well as, liquid nitrogen temperatures. As for ToshibaTMAmobeadsTMferrite cores, they are useful to block rapid-transition currents (spikes) at room, as well as, at liquid He temperatures. We also tested a permalloy-based RL filter, and found, that it is promising, but needs to be optimized.

Acknowledgments

The experimental studies and theory assessment of the results were supported by Russian Science Foundation (project No.16-12-10521). Fabrication of the RL filters was made by S. A. Chernyaev, K. V. Shein and A. G. Shukaleva, who acknowledge the support of Higher School of Economics project No.16-05-0029 "Physics of low-dimensional quantum systems".

5. References

- [1] Wellstood F C, Urbina C, and Clarke J 1994 Hot-electron effects in metals. *Phys. Rev. B*, **49** 5942-55.
- [2] Bladh K, Gunnarsson D, Hurfeld E, Devi S, Kristoffersson C, Smlander B, Pehrson S, Claeson T, Delsing P, and Taslakov M 2003 Comparison of cryogenic filters for use in single electronics experiments. *Rev. Sci. Instr.* **74** 1323-27.
- [3] Lee S H and Lee S-G 2016 Study on the fabrication of low-pass metal powder filters for use at cryogenic temperatures. *J. Korean Phys. Soc.* **69** 272-276.
- [4] Evetts N, Dosanjh P, Zvyagintsev V, and Hardy W N 2015 Note: A cryogenic, ultra-high-vacuum, microwave filter which passes a narrow beam. *Rev. Sci. Instr.* **86** 126101.
- [5] Kushino A and Kasai S 2015 Superconducting semi-rigid cable as low-pass filter for cryogenic readout. *J. Supercond. Novel Magn.* **28** 715-718.
- [6] Shnyrkov V I, Korolev A M, Turutanov O G, Shulga V M, Lyakhno V Y, and Serebrovsky V V 2015 Isolation of a Josephson qubit from the electromagnetic environment. *Low Temp. Phys.* **41** 867-873.
- [7] Tancredi G, Schmidlin S, and Meeson P J 2014 Note: Cryogenic coaxial microwave filters. *Rev. Sci. Instr.* **85** 026104.
- [8] Kasagi T, Tsutaoka T, Hatakeyama K 1998 High Frequency Permeability of Permalloy and its Composite Materials. *J. Magn. Soc. Japan* **22** No. S1_ISFA_97 S1_295-297.
- [9] MurataTMproduct catalog 2014 "SMD/BLOCK Type EMI Suppression Filters EMIFIL®". CAT No. c31e-26
- [10] Library for Cadence®PSPice®<http://www.murata.com/tool/library/pspice>.
- [11] Toshiba: Noise Suppression - AMOBEADS®
<https://toshiba.semicon-storage.com/us/product/amorphous/amobeads.html>